

FEATURES OF EBU11

- 2x 11 ton cylinders
- For Volvo/Renault/DAF/UD
- Hydraulic system
- Time saving
- Noise reduction
- 70 MPa system
- Control valve for crosswise pressing

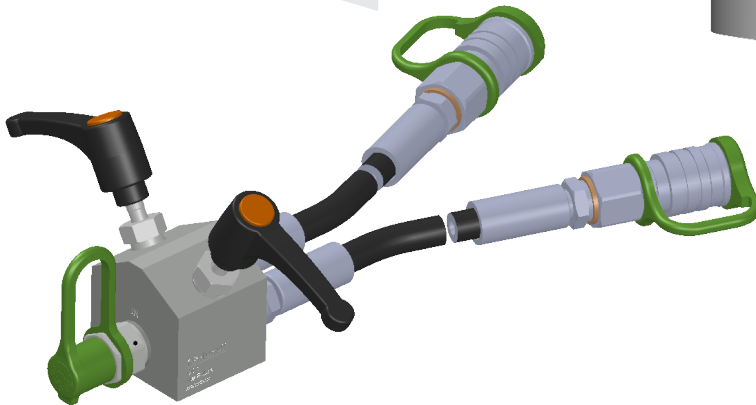
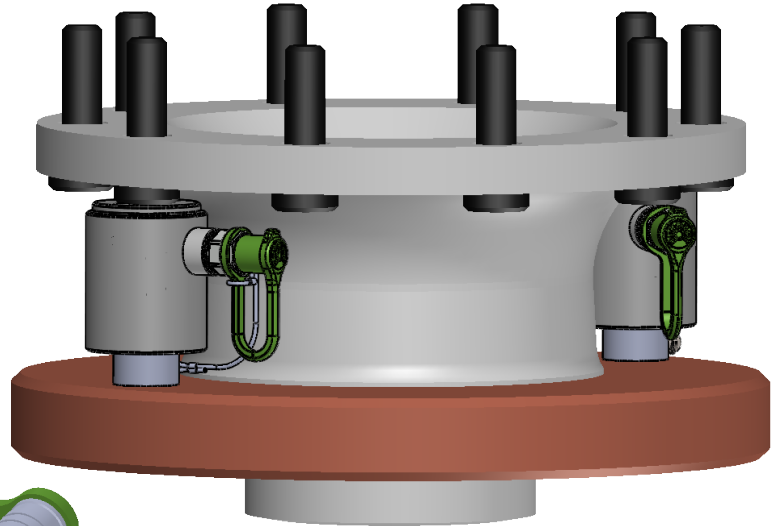

EBU11, Brake disc removal tool kit
22 TON PRESS FORCE!

Many trucks today is fitted with brake discs instead of brake linings. Use a tool adapt for such application, use Rehobot

■ **Information**



The brake disc removal tool EBU11 is a time saving, noise reduced and safe way for pressing out the disc with two compact cylinders. Use a hydraulic solution instead of an old fashioned hammer to prevent damaging the hub and put physical stress on the mechanic.

■ **Functionality**



The EBU11 tool does the job by evenly distribute the force on the disc with two 11 ton cylinders and a control valve for a crosswise pressing.

■ **Usability**



Truck models where EBU11 are applicable:

- Volvo
- Renault
- DAF
- UD
- And more!

PERFORMANCE

Type	Cylinders	Capacity/cylinder kN (ton)	Stroke mm	Total stroke volume cm³	Weight kg
EBU11	CLF110-30	111 (11)	28	89	6,7

MEASUREMENTS & COMPONENTS

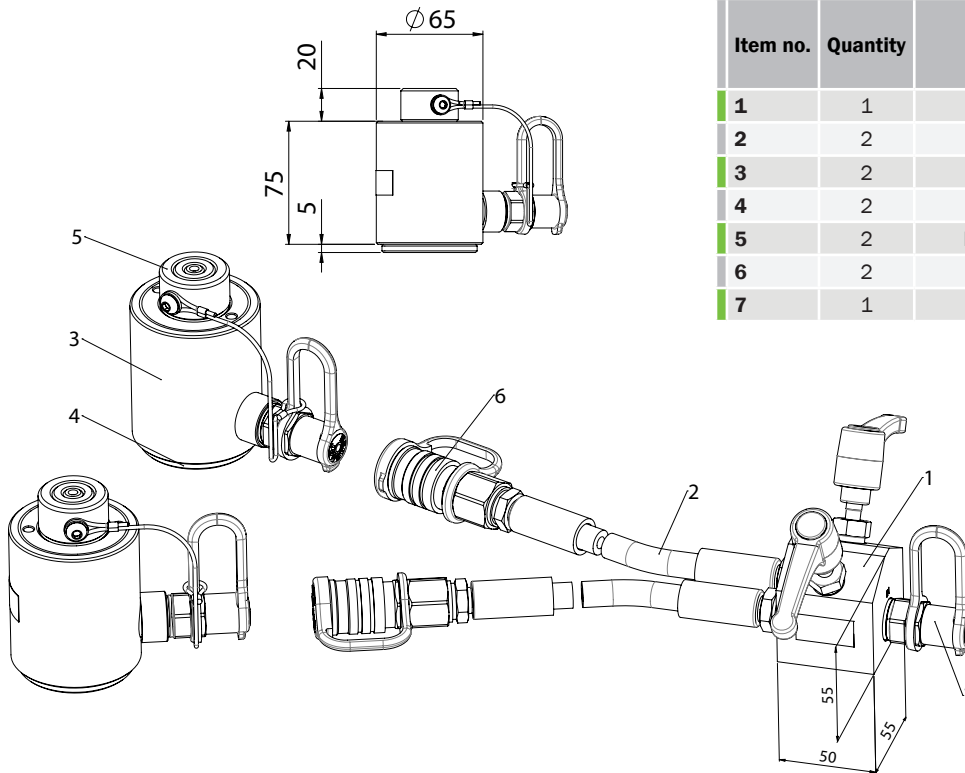

Item no.	Quantity	Description
1	1	Control valve
2	2	1,5m hose, LS150ES
3	2	Cylinder CLF110-30
4	2	Support plate
5	2	Extension pressure head Ø35
6	2	Quick coupling AQI7, female
7	1	Quick coupling AQU8, male

CONTROL VALVE

The manual operation control valve allows controlling movements and pressures to create a synchronized press. The precise control on the cylinders help the mechanic to prevent damage on the hub from uneven loading.

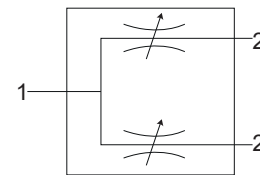

PUMP ALTERNATIVES

Air driven pump - for more comfort



PP70B-1000
 PP70B-1000/LS201 (2 m hose, female quick coupling and swivel)
 PP70B-1000/LS250 (2.5 m high flex hose, quick coupling and swivel)

Hand pump - more portable



PHS70-1000
 PHS70-1000/LS201 (2 m hose, female quick coupling and swivel)
 PHS70-1000/LS301 (3 m hose, female quick coupling and swivel)
 PHS70-1000/LS250 (2.5 m high flex hose, quick coupling and swivel)

ORDER INFORMATION

Designation	EBU11 - Brake disc remover tool kit
Part number	52073