

SPECIFICATIONS

- 70 MPa / 700 Bar / 10.000 psi
- Usable oil capacity, 2.5 or 5 l
- Adjustable pressure 0-70 MPa
- Noise level <80 dB
- Unique compact design
- Low weight and low point of gravity
- Aluminium oil container
- Oil fill cap with vented plug
- Ø100mm Cl. 1 gauge included
- 0,25kW or 0,55kW. 230VAC/50Hz
- Pendant control IP65
- Time relay shut-off at return
- 2x built in safety vales at P and R

Torque Wrench Pump

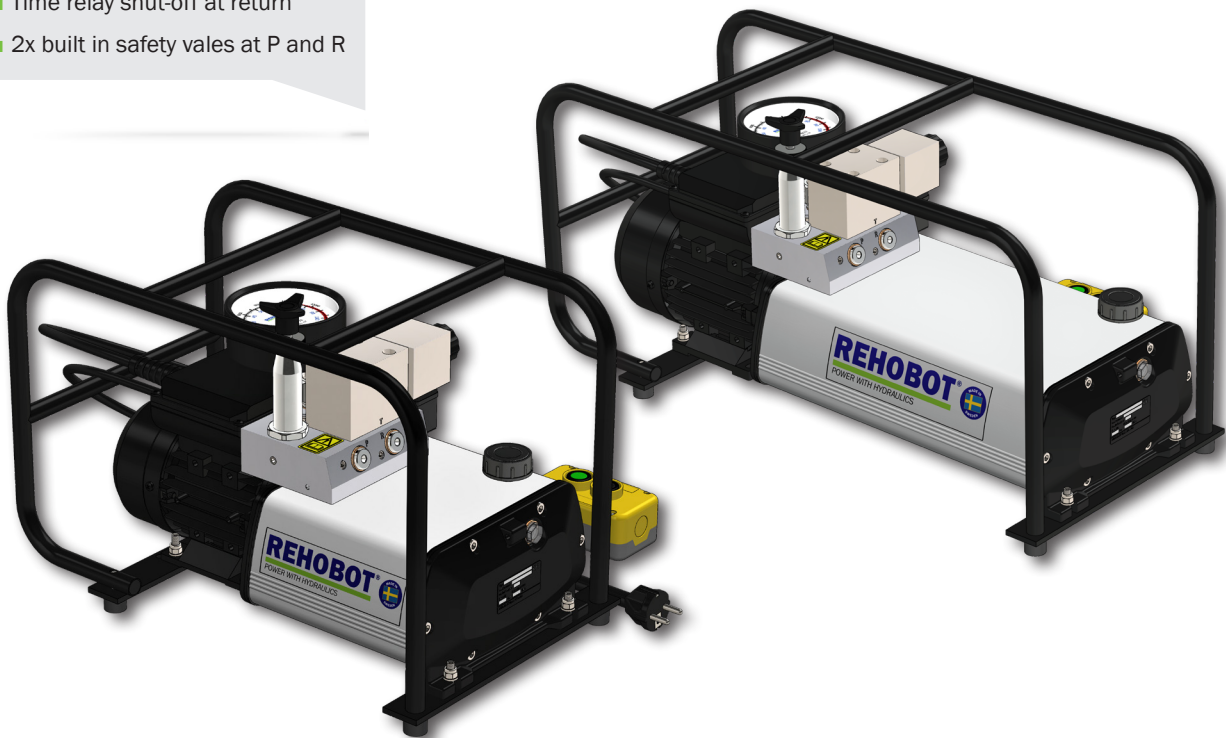

Information



Unique compact design with low weight and low point of gravity.
Robust and durable with aluminium oil container.
Low maintenance induction motor.
Low noise level - under 80 dB.
Oil fill cap with built in air vent in both directions.
Build in safety valves set at max. working pressure and max. return pressure.
External pressure regulating valve with locking ring. Steel bar frame enclosing and protecting the pump.

Functionality



Pumps can start under full load.
IP67 pendant control.
One button - two functions, changed with a 0/1 switch.
Switch mode 1 enable push and hold for running the pump and activating the tool. Release of button automatically reverse the direction and tool retracts. Motor stops after 10 seconds if button is not pressed again.
Switch mode 0 stop motor and enable push and hold to release any pressure eventually left in the tool.

Usability



Designated Torque Wrench Pump.
For intermittent use in service applications.

- Wind Power Plants
- Oil Refineries
- Industrial Bolting Applications
- Heavy Machinery
- Mining Facilities

REHOBOT Hydraulics AB

Postal address: P.O. Box 1107
631 80 Eskilstuna, Sweden
T: +46 (0)16-16 82 00 | F: +46 (0)16-13 93 16
E: info@rehobot.se | www.rehobot.se

REHOBOT Ltd.

Unit 6, Stechford Trading Estate, Lyndon Road, Stechford
Birmingham B33 8BU, UK
T: +44 121 789 77 07 | F: +44 121 789 68 66
E: info@rehobot.co.uk | www.rehobot.co.uk

REHOBOT Inc.

Unit #1 3980 W. Albany St.
McHenry IL 600 50, USA
T: +1 815 385 77 77 | F: +1 815 385 77 76
E: info@rehobot.us | www.rehobot.us

PERFORMANCE & DATA

Designation	Item code	Working pressure (MPa)	Eff. oil vol. (cm ³)	Capacity (cm ³ /min)		Motor (V/Hz/kW)	Gauge		Weight (kg)
				High pressure	Low pressure		Type	Size / Class	
PME025/70-2500TW	52490	70	2500	240	3000	230/50/0,25	AMT803	Ø100 / 1	20,9
PME055/70-2500TW	52529	70	2500	450	3900	230/50/0,55	AMT803	Ø100 / 1	23,5
PME055/70-5000TW	52530	70	5000	450	3900	230/50/0,55	AMT803	Ø100 / 1	27

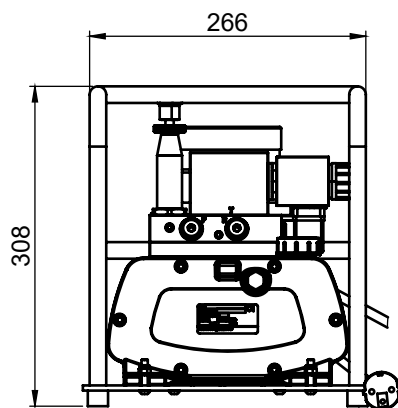

PME -2500TW

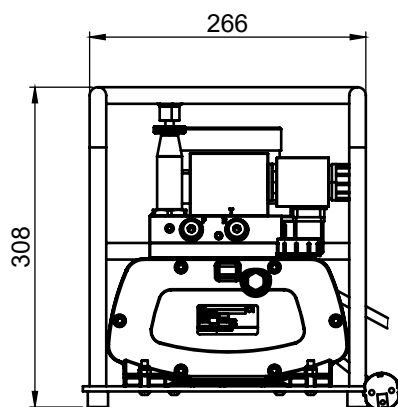
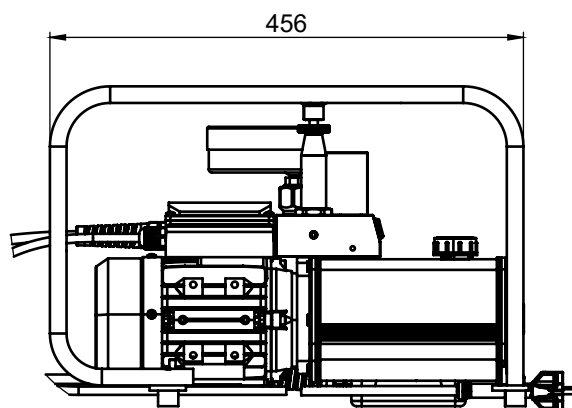

PME -5000TW

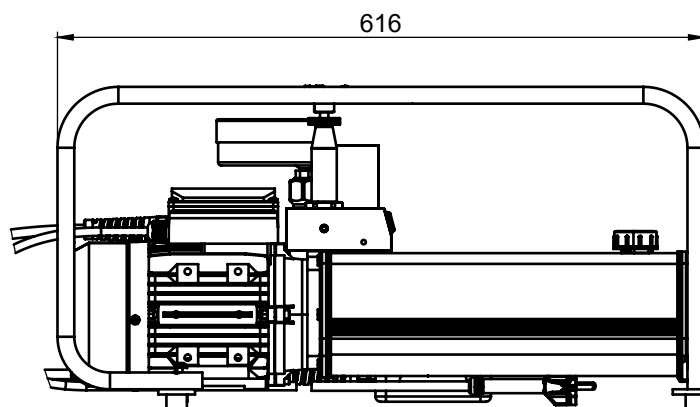

Electric component	Cable Material	Length*	Additional information
Power Cord	H05RN-F	2 m	Plug CEE 7/7
Pendant Control	H07RN-F	3 m	IP65 hand held pendant control

*) For alternative length, contact REHOBOT.