

### FEATURES OF THE TPP63

- Perform operation in situ
- 63 ton capacity
- Cylinder CHF63-60 included
- Working pressure 70 MPa
- Accessories for different track chain sizes included
- Assemble tool in place for easy handling.

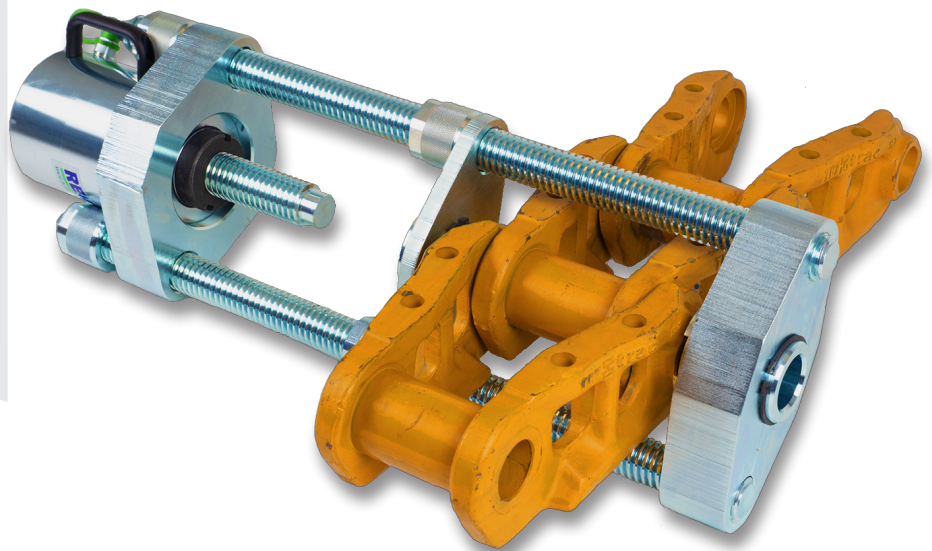

## 63 TON HYDRAULIC TRACK PIN PRESS TPP63

Designed for in situ removal and installing the end bolt for a variety of track chain sizes on excavators.

### ■ Information



The hydraulic Track Pin Press, TPP63 is a pressing tool used to remove and installing the end bolt on track chains on excavators. The tool can be used in situ to save time. Just install the tool part by part in place, connect a hydraulic pump and go.

### ■ Functionality



The TPP63 has a pressing capacity of 63 metric ton and comes with 6 different sized combinations of mandrel and centering sleeves for a number of different track sizes.

### ■ Usability



Fields of use where the TPP63 is applicable may include:

- Forest machinery
- Construction sites
- Mining facilities
- Landscaping operations

**TECHNICAL DATA**

Product	Capacity		Max working pressure		Stroke		Stroke volume		Connection	Weight, total		Weight, tool	
	kN	ton	MPa	psi	mm	in	cm <sup>3</sup>	in <sup>3</sup>	Quick coupling	kg	lbs	kg	lbs
TPP63	625	63,7	70	10500	60	2.36	536	32.7	AQU8 (male)	94	207.3	~66	~145.5

**MEASUREMENTS**

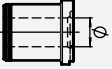
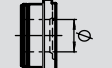
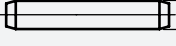
pos.	Drawing	Track size					
		A	B	C	D	E	F
1		36 mm	39,5 mm	41 mm	47,5 mm	50,5 mm	53,5 mm
		1.42 in	1.56 in	1.61 in	1.87 in	1.99 in	2.11 in
2		36 mm	39,5 mm	41 mm	47,5 mm	50,5 mm	53,5 mm
		1.42 in	1.56 in	1.61 in	1.87 in	1.99 in	2.11 in
3		31,5 mm	35,5 mm*	35,5 mm*	43 mm	45 mm	48,5 mm
		1.24 in	1.40 in*	1.40 in*	1.69 in	1.77 in	1.91 in

\*) Same mandrel used with both B and C centerling sleeves

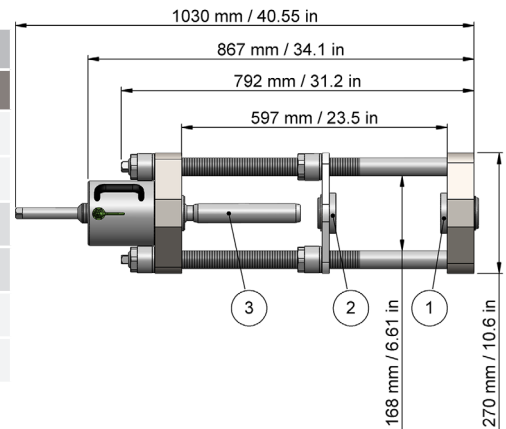

**IN SITU ASSEMBLY AND OPERATION**

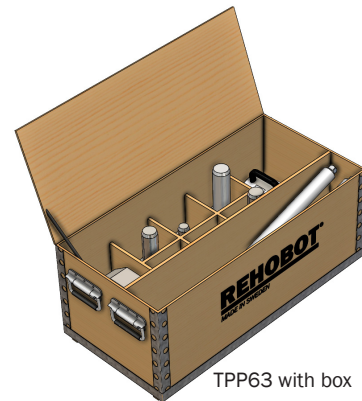
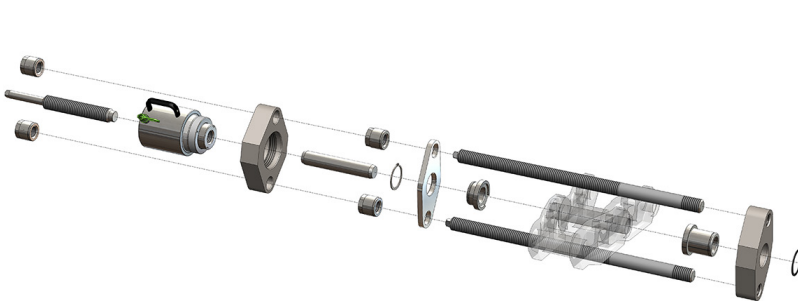
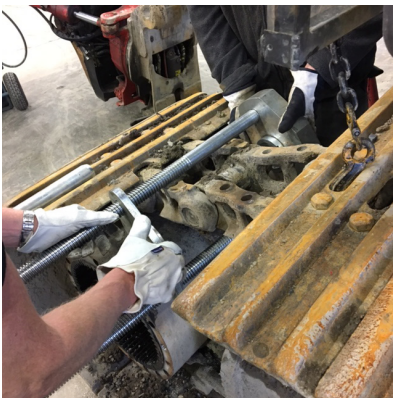

TPP63 with box

**ORDERING INFORMATION**

	Toolset		Recommended pumps - NOT included	
<b>Info</b>	Track Pin Press		Hand pump with hose, quick coupling and gauge	Air driven pump with hose and quick coupling
<b>Designation</b>	TPP63	TPP63 with box	PHS70-1000/LS201	PP70B-1000/LS201
<b>Part number</b>	51400	51953	44414	49306